

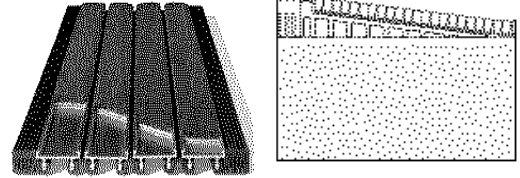

Installation Instructions

Peditred G4 with Pipestem Frame



1). Site Prep

- Clean the floor surface to remove all dirt, oily film, and debris.
- Locate and mark final location in which the Peditred will be placed.

2). Assemble Frame

- The frame pieces have been pre-mitered to allow for quick assembly.
- Remove the protective layer of the tape, which is adhered to the bottom of the frame, and set in its final location.(See Illustration A)

(Note: 3/16" masonry anchors can be used to fasten the frame in high traffic applications)



Illustration A

3. Peditred Installation

Locator Bars are included with the hardware package and must be installed to ensure proper alignment of the Peditred rails.

- Upon final location of the Peditred within the frame, mark the treadrail centerline of the first and second rail on the exposed frame surface at each corner location.

(Illustration B)

- Position the locator bar along the marked line. (Illustration D)
- Using the locator bar as a guide, drill a pilot hole with a 5/32" masonry bit.
- Using a #2 Phillips drive, secure each locator bar with two 3/16" masonry anchors.

(Illustration C)

- Attach two locator bars per corner.

- Install Peditred.

B

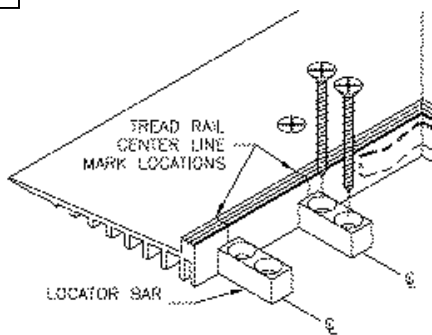

C

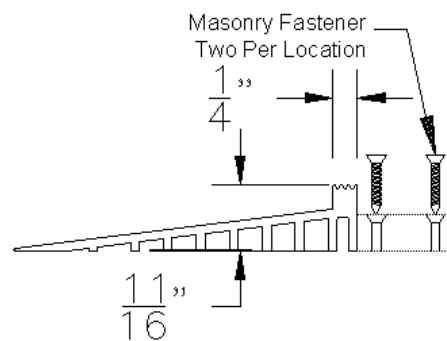

D

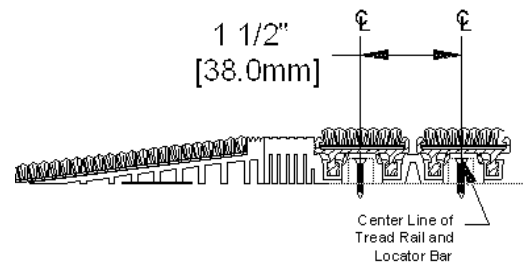

4.) Attaching Modules (If Necessary).

- Attach modules 1,2, and 3 (Illustration E & F) together as shown below utilizing a rubber mallet.
- Depending on the size of the Peditred, there may be multiple modules needed to make one complete unit. These modules must be joined together as shown in (Illustration E)

Illustration E

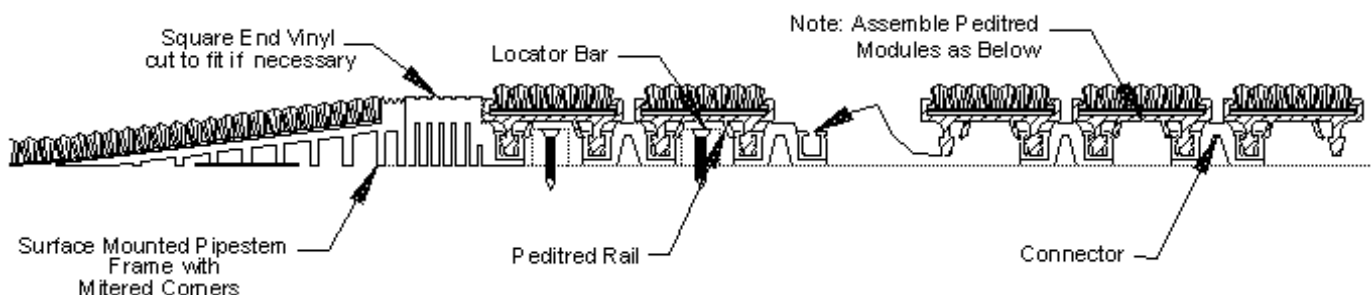

5.) Splice Connections for Large Grids Over 144" Wide

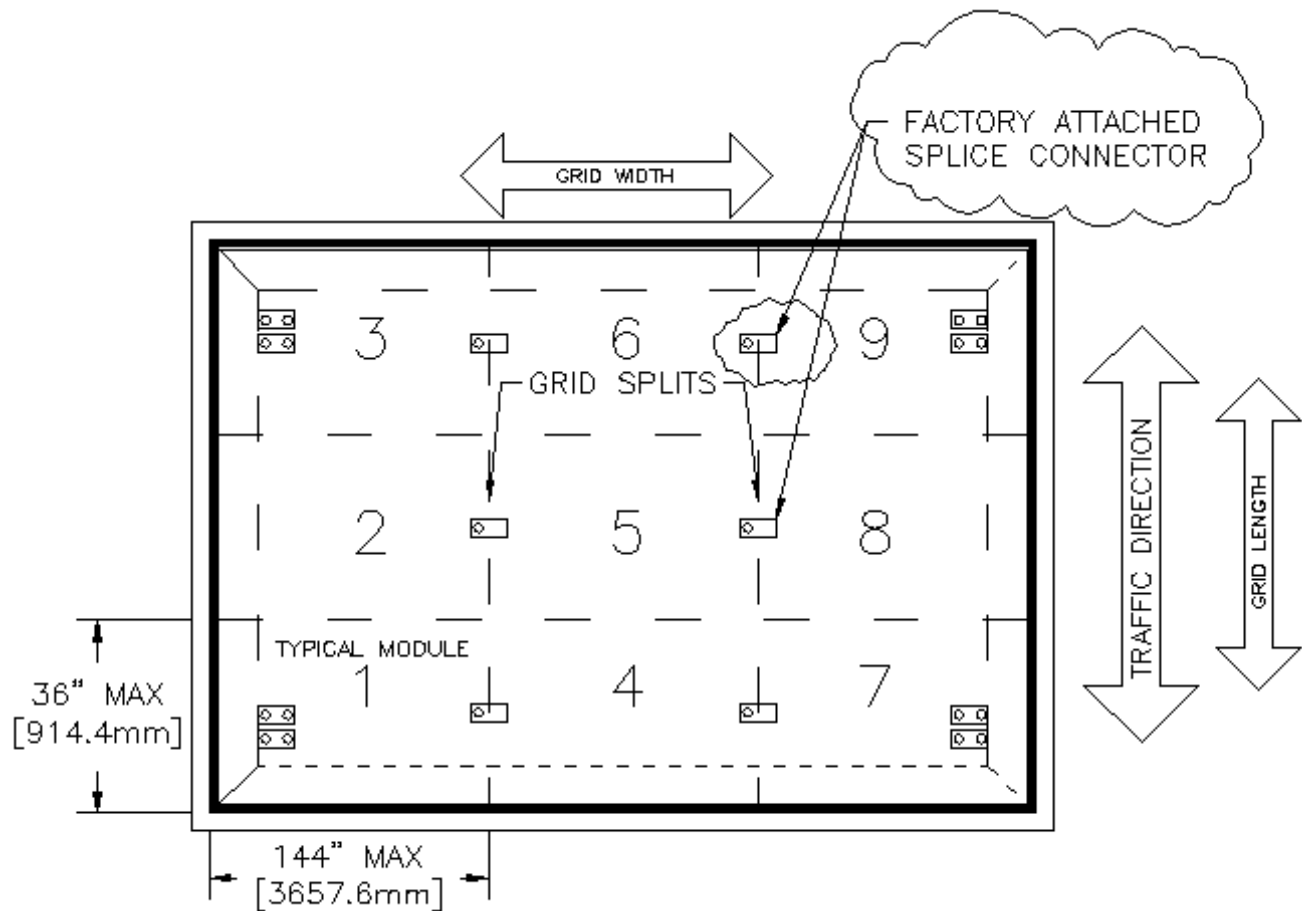

Illustration F

- Trial fit assembly into frame area. Trim end vinyl as required with a utility knife for proper fit.
- Align and secure center tread rail with factory attached splice connector.

(Illustration G)

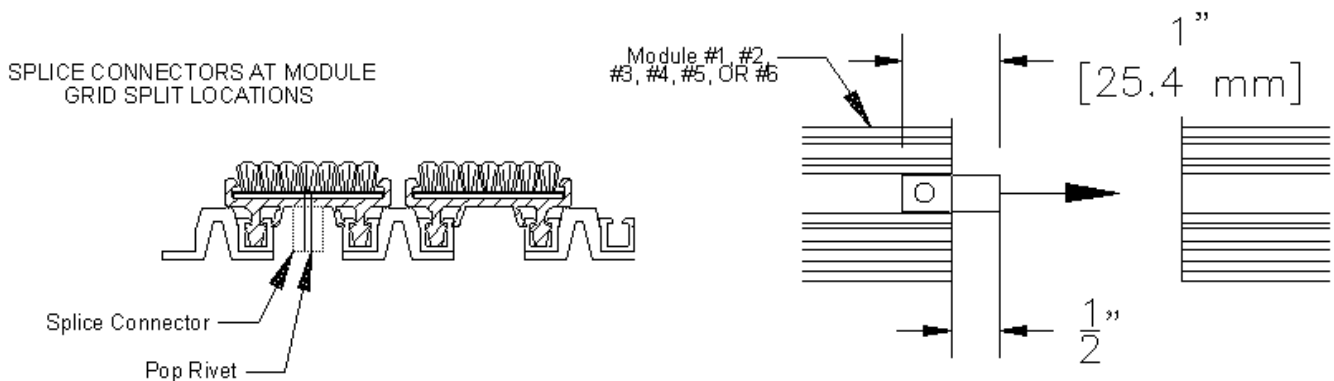

Illustration G

FAQ on this step

Q: Why is my Peditred larger or smaller than the opening between the frames?

A: The vinyl carriers on the underside of the Peditred may expand or contract during shipping. If the Peditred is smaller than the opening, simply roll up and unroll the grid. This will stretch the carriers and allow it to expand. If the Peditred is larger, tuck the end vinyl into the recess and compress the rails flat. End vinyl may need to be trimmed.

6.) Completion

It is necessary to cover the installation with ¾” plywood until all additional project work is completed. This will protect the Peditred from potential abuse during the construction phase. Damage occurring from inadequate protection during this phase may void the manufacturer’s warranty.

7.) Care and Maintenance Instructions

- **Manufacturer’s suggested safe rolling load for the Peditred G4 is 1000# per wheel. Heavy loads beyond this weight may damage the units, contributing to their premature failure or creating a tripping hazard.**
- **Clean the recess – roll back the unit and clean the recess as frequently as necessary. This will prevent an excess buildup of dirt under the grids. Do not roll the unit too tightly.**
- **Clean the carpet. To extend the life of the carpet, vacuum frequently and shampoo occasionally.**
- **Replacement inserts can be purchased to renew the look and function of your unit. Call us at 800-233-8493 (US) or 888-895-8955 (Canada) and our sales group will assist you with pricing, color selection, and installation instructions.**