

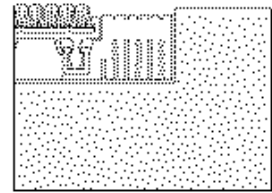

Installation Instructions

Peditred G4 with No Frame

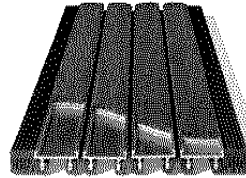

1). Site Prep

- Use wood forms to prepare a recess in the concrete a minimum 11/16" depth to final finished floor surface.
- After concrete has cured, remove the wood forms. (See Illustration A) below
- Clean the concrete recess to remove all dirt, oily films, and debris.

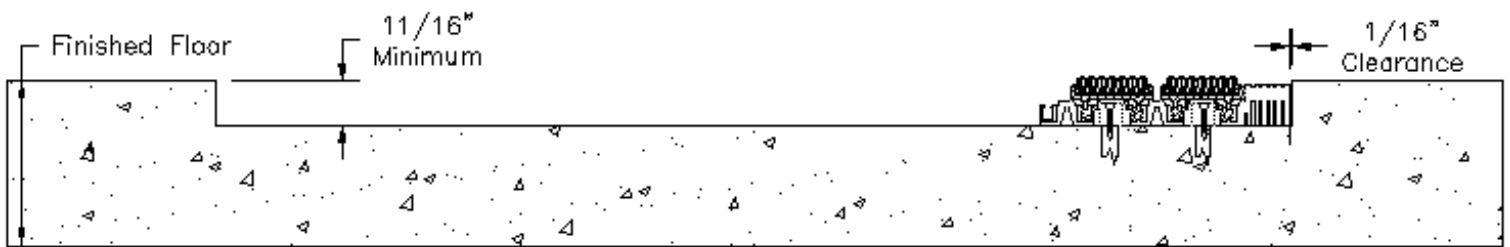
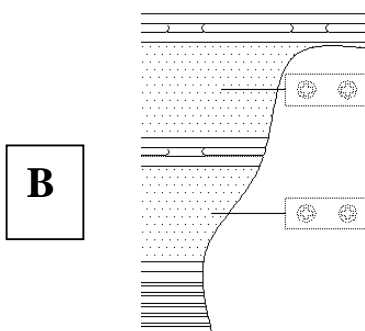

Illustration A

2.) Peditred Installation

Locator Bars are included with the hardware package and must be installed to ensure proper alignment of the Peditred rails.

- Upon final location of the Peditred within the recess, mark the treadrail centerline of the first and second rail at each corner location. (Illustration B)
- Position the locator bar along the marked line. (Illustration D)
- Using the locator bar as a guide, drill a pilot hole with a 5/32" masonry bit.
- Using a #2 Phillips drive, secure each locator bar with two 3/16" masonry anchors. (Illustration C)
- Attach two locator bars per corner.
- Install Peditred.



B

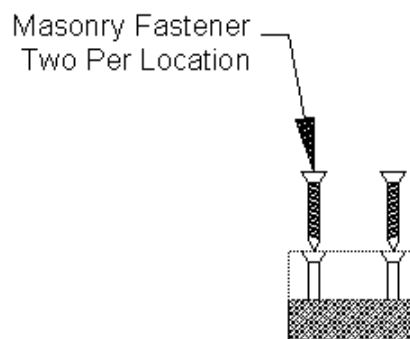

C

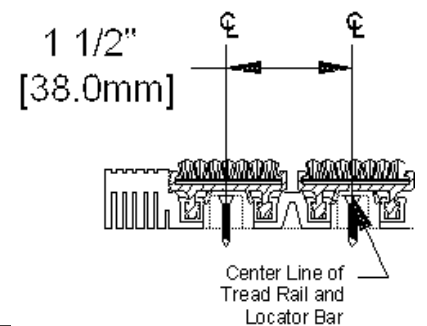

D

3.) Attaching Modules (If Necessary).

- Depending on the size of the Peditred, there may be multiple modules needed to make one complete unit. These modules must be joined together as shown in illustration E.
- Attach modules 1,2, and 3 (example) together as shown below utilizing a rubber mallet.

Illustration E

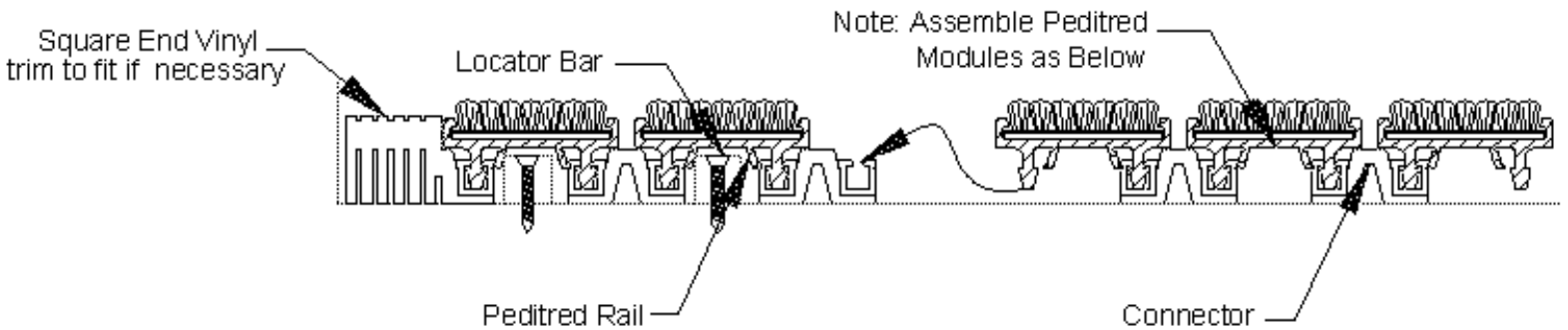

4.) Splice Connections for Large Grids Over 144" Wide

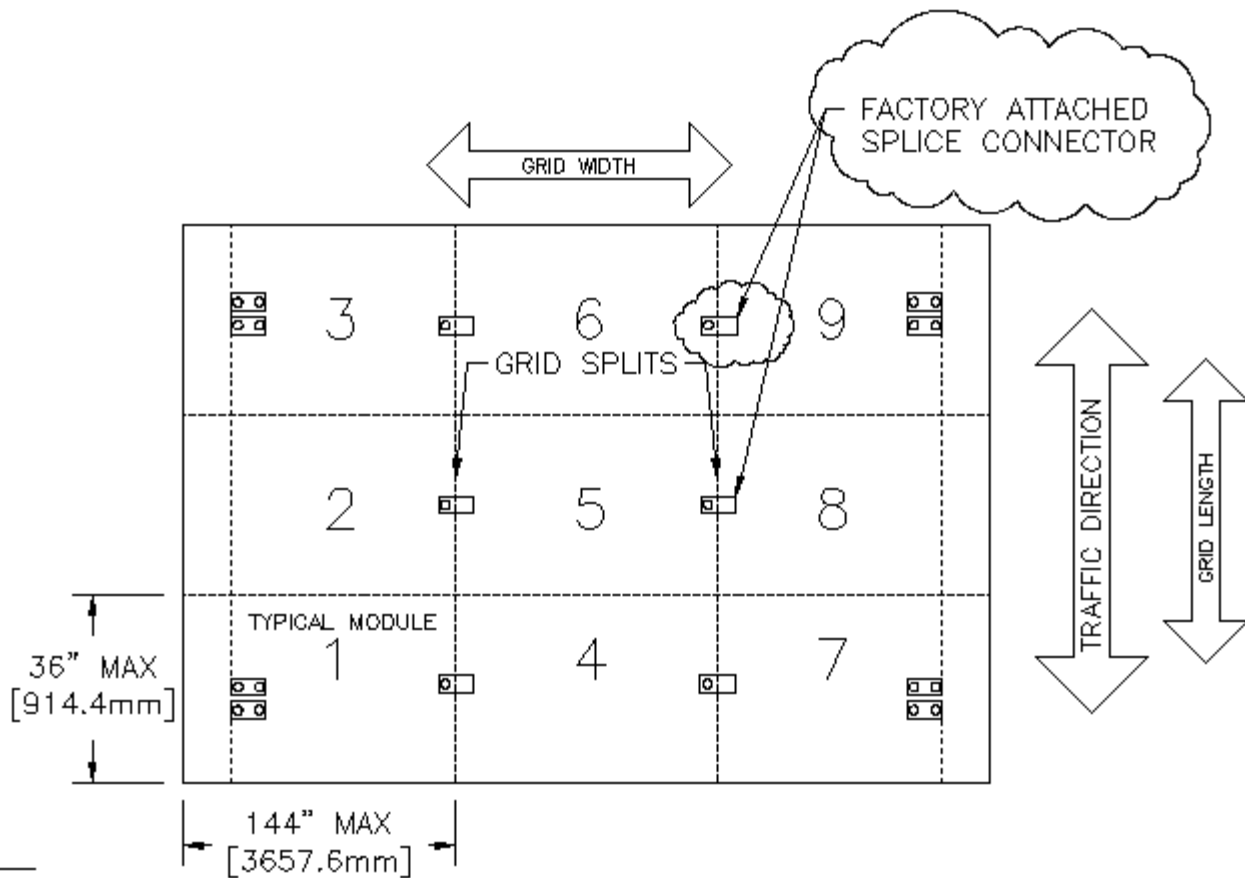
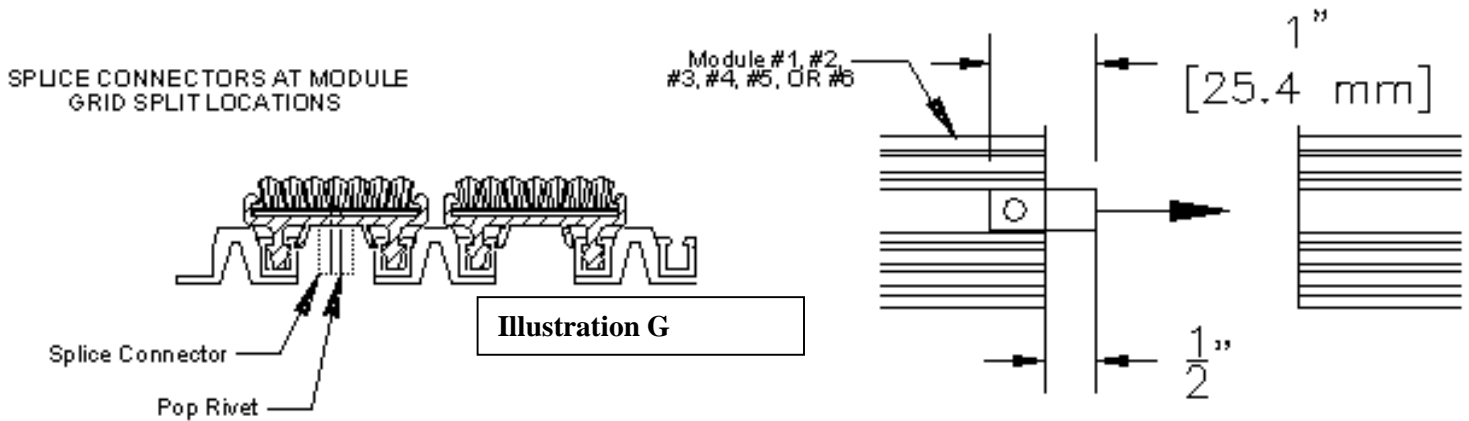

Illustration F

- Trial fit assembly into frame area – trim end vinyl as required with a utility knife for proper fit.
- Align and secure center tread rail with factory attached splice connector.



FAQ on this step

Q: Why is my Peditred larger or smaller than the recess?

A: The vinyl carriers on the underside of the Peditred may expand or contract during shipping. If the Peditred is smaller than the recess, simply roll up and unroll the grid. This will stretch the carriers and allow it to expand. If the Peditred is larger, tuck the end vinyl into the recess and compress the rails flat. End vinyl may need to be trimmed.

5.) Completion

It is necessary to cover the installation with 3/4" plywood until all additional project work is completed. This will protect the Peditred from potential abuse during the construction phase. Damage occurring from inadequate protection during this phase may void the manufacturer's warranty.

6.) Care and Maintenance Instructions

- **Manufacturer's suggested safe rolling load for the Peditred G4 is 1000# per wheel. Heavy loads beyond this weight may damage the units, contributing to their premature failure or creating a tripping hazard.**
- **Clean the recess – roll back the unit and clean the recess as frequently as necessary. This will prevent an excess buildup of dirt under the grids. Do not roll the unit too tightly.**
- **Clean the carpet. To extend the life of the carpet, vacuum frequently and shampoo occasionally.**
- **Replacement inserts can be purchased to renew the look and function of your unit. Call us at 800-233-8493 (US) or 888-895-8955 (Canada) and our sales group will assist you with pricing, color selection, and installation instructions.**